



Structural Lightning Protection System
(IS/IEC 62305-1 to 4/NBC)





Structural Lightning Protection System

INTRODUCTION

What happens when lightning strikes near you?

When lightning strikes at a point, it brings down a huge amount of charge, which flows in all directions until all the charges are neutralized by opposite charges in the earth. There could be charges flowing from surrounding areas towards the point of strike too, as a bolt of lightning has short pulses of current going up as well as coming down. As the charges flow along the ground, constituting an electric current, it produces a voltage difference between points. The voltage difference depends on the amount of current flowing (I) and the resistance between the points (R). This voltage difference is given by the equation $V = IR$. Obviously, the value of R is determined by several factors such as the conductivity of the soil (which in turn depends on the moisture in the soil)

and the distance between the points. Therefore, if the points are separated by a large distance, the resistance will be large and the voltage also will be large. Such a voltage between two points on the ground separated by a distance is called step voltage. As the current in a lightning bolt is on the order of tens of kilo amperes, the voltages also can be very large. Therefore, if you happen to be near the point where lightning strikes and you happen to be standing with your feet apart or lying down on the ground, you could experience a large voltage between your feet touching the ground or between your feet and your head. In the former case, you could get a nasty shock on your legs as the current enters your body through one leg and leaves through the other. This could cause you to lose your balance and fall or be thrown over a short distance. In either case, you could get hurt, sometimes seriously too.



If you happen to be lying down, the voltage difference will be much larger and the lightning current could flow through your body, from head to toe or toe to head. In either case, it passes through your torso. A tiny part of it could go through your heart, in which case, it could result in the fibrillation of your heart, which could kill you if you don't get immediate medical care.

Lightning can happen in different circumstances. The most common among them is the thunderstorm or technically, the Cumulonimbus

cloud. Lightning can also happen during volcanic eruptions and dust storms (possibly in other situations too). But we will discuss only how lightning happens in Cumulonimbus clouds.

Cumulonimbus is a huge type of cloud that grows from about 1–2 km height above the earth's surface to the top of the troposphere (the lowest layer of the atmosphere), also known as the tropopause. The tropopause is at a height of about 17 km in the tropics, but comes down to about 11 km near the poles. Therefore, cumulonimbus clouds are about 15 km tall in the tropics, but only about 10 km tall in the temperate regions. There are mainly three types of cumulonimbus, namely, the single-cell type, the multi-cell type and the super cell type. The last one is much bigger and can be a couple of hundred kilometers in diameter, but they grow only when there is vertical wind shear, that is, when the direction of the wind changes with height. They are much more destructive than the single cell type that we see mostly in this part of the country (South-West coast of India). Single cell thunderstorms are usually about 20 km in diameter. The peculiar feature of thunderstorms is that, as they grow so tall, they cross the level in the atmosphere where the temperature falls to zero. Therefore, these clouds have water in all three states in them, namely, water vapor, liquid droplets and small ice flakes.

In a process that is not yet clearly understood,



the presence of the three phases of water and the powerful circulation inside the cloud causes electrical charges to separate with the positive charges moving mostly up and the negative charges moving mostly down, though we find charge accumulations in other parts of the cloud too. While air is normally an insulator of electricity, when the charge accumulation continues for some time and the electric potential differences increase beyond a certain limit, the insulation of air breaks down and electrical energy starts flowing through it. As you know, a flow of electricity through any material causes it to heat up. So air also heats up. As the current that flows through air in a lightning discharge is huge, around 30,000 amperes, this causes the air in the channel to become extremely hot, again around

30,000 C. This is about five times the temperature



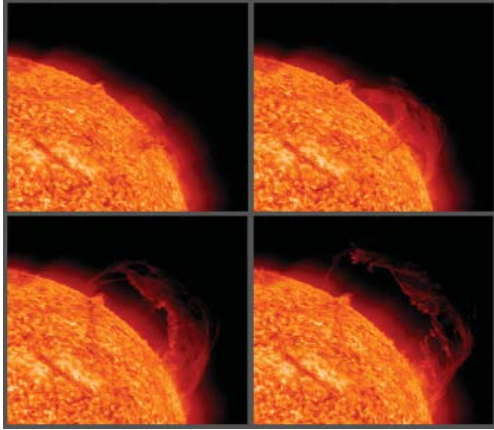

of the surface of the Sun. So, the air expands suddenly, causing a shock wave,

which we call thunder. Hope this clears your doubt. Lightning is formed by the the most air inside a cloud being buffeted by the winds. The droplets of water and ice rub together and a static electric charge is produced. It's a bit like when you pull a jumper made of certain synthetic materials over your head and in the dark you can see tiny sparks or arks of energy.

The voltage in relation to your jumper trick is probably a few thousand volts but the current is very low so you may feel a little tickle as the voltage discharges but it will not kill you.

Do remember when we talk about lethal voltage we must also consider the current. We were always told, voltage shocks current kills.

Back to the clouds. The charge that builds up in

a cloud is caused by positively charged (lighter) particles move to the top of the cloud and negatively charged (heavy) particles move to the bottom of the cloud. Once the charge is high enough a spark inside the cloud discharges this build up of static charge and we see the flash. Themajority of discharges occure inside the clouds but in certain circumstances the air below a storm cloud becomes positively charged due to the effects of the high negative charge in the base of the cloud. As this ground charge builds a point can arrive where we get a ground strike normally via a tall mast, tree or lightning conductor on a building.

A few facts. The static charge that builds up in the clouds is is huge. We are talking maybe 1 billion volts. The current during a discharge event can be 10,000 to 200,000 amps. The last thing to remember is the duration of these events is generally tiny. In the region of micro seconds which is 1 millionth of a second. As such although these events can kill or cause considerable damage when we have a ground strike the power is well below that which we use to keep a worlds machines turning and our lights on.

This is a very compressed version of the entire lightning story but hope it gives you a flavour of these volatile events.

How does lightning happen?

What causes lightning?



Lightning strikes!

Have you ever got a static electricity shock? Or seen sparks when you take off your jumper? When lightning is made the same thing happens, but on a much bigger scale.

How does lightning form?

Lightning is an electric current. To make this electric current, first you need a cloud.

When the ground is hot, it heats the air above it. This warm air rises. As the air rises, water vapour cools and forms a cloud. When air continues to rise, the cloud gets bigger and bigger. In the tops of the clouds, temperature is below freezing and the water vapour turns into ice.

Now, the cloud becomes a thundercloud. Lots of small bits of ice bump into each other as they move around. All these collisions cause a build up of electrical charge.

Eventually, the whole cloud fills up with electrical charges. Lighter, positively charged particles form at the top of the cloud. Heavier, negatively charged particles sink to the bottom of the cloud.

When the positive and negative charges grow large enough, a giant spark - lightning - occurs between the two charges within the cloud. This is like a static electricity sparks you see, but much bigger.

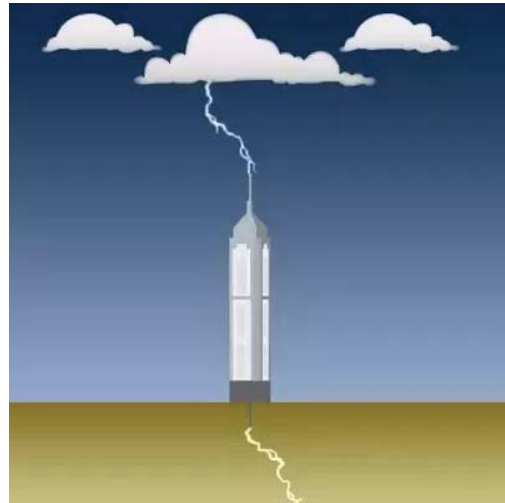

Most lightning happens inside a cloud, but sometimes it happens between the cloud and the ground.

A build up of positive charge builds up on the ground beneath the cloud, attracted to the negative charge in the bottom of the cloud. The ground's positive charge concentrates around anything that sticks up - trees, lightning conductors, even people! The positive charge from the ground connects with the negative charge from the clouds and a spark of lightning strikes.

An average bolt of negative lightning carries an electric current of 30,000 amperes (30 kA), and transfers 15 coulombs of electric charge and 500 mega joules of energy. Large bolts of





negative lightning can carry up to 120 kA and 350 coulombs.

Lightning strikes are actually so powerful that they can be picked up by AM radio in between radio bands. Because of the way the static effects that medium.

The average positive ground flash has roughly double the peak current of a typical negative flash, and can produce peak currents up to 400,000 amperes (400 kA) and charges of several hundreds coulombs.

Furthermore, positive ground flashes with high peak currents are commonly followed by long continuing currents, a correlation not seen in negative ground flashes.

As a result of their greater power, as well as lack of warning, positive lightning strikes are considerably more dangerous. Due to the aforementioned tendency for positive ground flashes to produce both high peak currents and long continuing current, they are capable of heating surfaces to much higher levels which increases the likelihood of a fire being ignited.



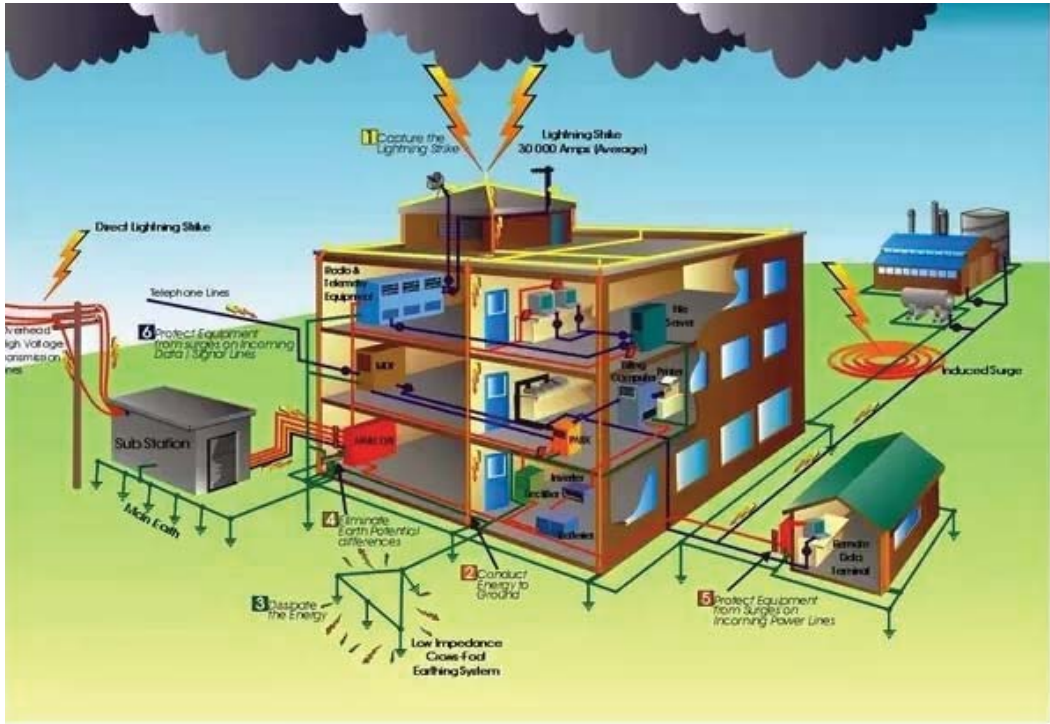

Single lightning bolt is about 50,000° F or 5 times hotter than the surface of the sun. A lightning bolt is anywhere from 1,000,000 to 1,000,000,000 volts and between 10,000 and 200,000 amps. Or about 215 kWh. The average lightning bolt could light a 100 watt light bulb non-stop for about 3 months. The thickness of a lightning bolt is about the size of a silver dollar. It only looks bigger because it is so bright. Lightning causes objects to explode because it instantly turns any water to steam. This includes concrete, trees, asphalt and clothes.

Lightning is an Impulse current.

An AC current is alternating in nature i.e. it's value moves between high and low continuously. There is a frequency of this high and low movement of the AC current. Whereas a DC current is constant in nature. It does not change its polarity as well as magnitude with time.

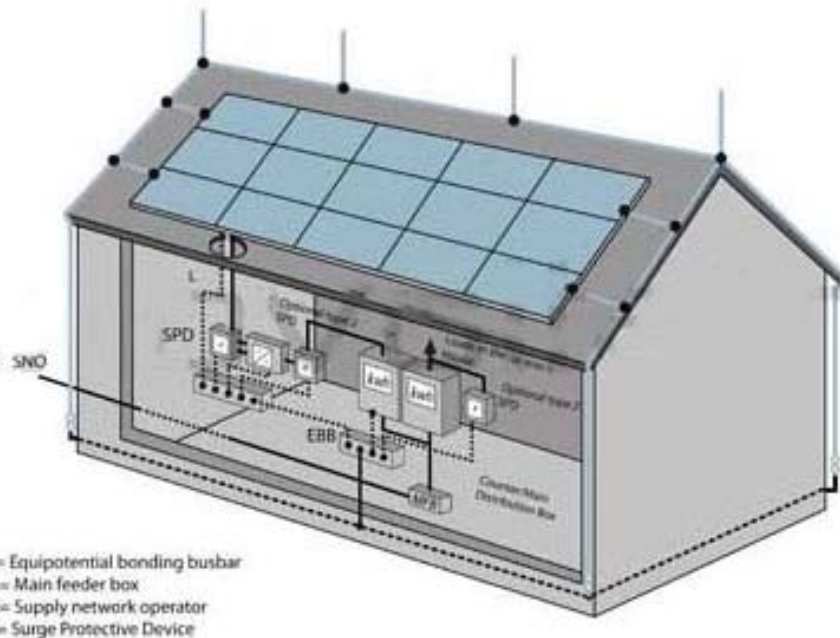

Now, Lightning is a short circuit between the ground and the clouds above us or short circuit between the clouds. This short circuit does not happen because of potential difference but because of charge density in the cloud. When friction happens between clouds different static electric charges are accumulated in the clouds. With time once the charge density increases to a certain level (it is variable from place to place depending on the contaminants, temperature, moisture content etc in the cloud) air breaks down near the cloud and charges propagate. Many often this propagation continues until it

reaches the ground. In other times there is short circuit between the clouds of different charges. From the above it can be understood that lightning is a short lived phenomenon. And it does not resemble with either AC or DC current. It has similarity only with impulse and that is why it is called lightning impulse.

All the high voltage power system equipment are subjected to lab generated lightning impulse to test their ability to perform under lightning in real life environment.

Air-Termination Lightning Protection System

Benjamin Franklin invented the Lightning Rod in 1753. This lightning conductor is made up of a 2 to 8 m high tapered metal rod that dominates the structure to be protected and which is connected to minimum two down conductors and two earthing system.

As the protection radius of this type of Air-Termination Rod is limited to around 30 meters environ (Lightning Protection Level = IV, height = 60 meters), it is normally only used to protect small structures or zones such

as pylons, chimneys, tanks, water towers, aerial masts, etc...

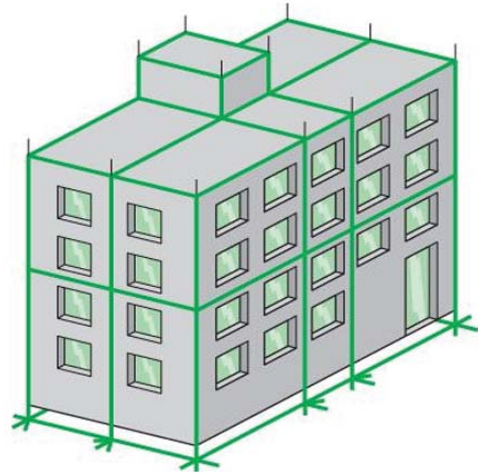

conductors are subjected to the same rules as for the meshed conductors lightning protection system.

Meshed Conductors Lightning Protection System

Typical example

Protection of an external explosive storage area by a catenary wire lightning conductor

This lightning protection system, using a similar principle to that of the mesh cage, consists of a mesh of conductors, but at a distance from the structure to be protected. The aim is to avoid the lightning current coming directly into contact with the structure.

Catenary wire conductors placed above the structure to be protected are connected to down conductors and dedicated earthing systems. The size of the mesh and the distance between down

This protection requires that additional mechanical studies (resistance of materials for masts, qualifying ground pressure, resistance to wind and weather condition, etc.) be carried out and insulation distances defined. The catenary wire lightning conductor is particularly used to protect open areas when there is no architectural support or hazardous storage.

Column or wall reinforcement can be used as part of the lightning protection system.

- It is normal to designate a bar in each lift that differs from the others by being slightly longer and or a larger



diameter. Each bar must be electrically connected to the next with an appropriate tape clamped to both bars.

Typical example

Protection of a building using a mesh cage lightning conductor This lightning protection, derived from the Faraday cage, consists of meshed conductors that cover the roof and walls of the structure to be protected. Air terminals are positioned around the edge of the roof and on high points. A network of conductors follows the external perimeter of the roof. This network is completed with transverse elements. The mesh size is between 5 and

20 meters according to the effectiveness required. The top of the down conductors fitted to the walls are connected to the roof mesh, and the bottom to dedicated earthing systems. The distance between two down conductors is between 10 and 20 meters according to lightning protection level required. The largest part of lightning current is conducted and dissipated through the conductors and earthing systems closest to the point of impact of the lightning strike. Catenary wire lightning conductor

ANGLE METHOD

According to this method, the protection volume is given by a line starting at the air terminal, the angle of which depends on the height and the protection level, according to the following graph:

Franklin rods should be placed on the higher and most vulnerable places (corners, overhangs, etc.), as shown in the figure:

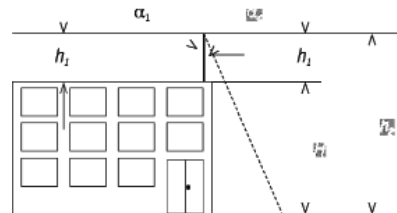
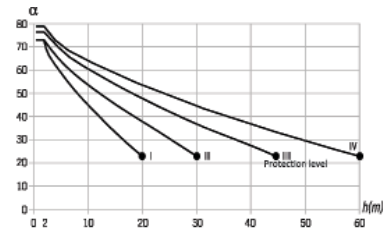

MESH METHOD AS PER IEC 62305-3



According to this method, conductors forming a mesh should be placed on the structure. The separation depends on the protection level:

Protection level		
Protection level	Mesh	Distance between down- conductors
I	5 x 5 m	10 m
II	10 x 10 m	10 m
II	15 x 15 m	15 m
IV	20 x 20 m	20 m

ROLLING SPHERE METHOD AS PER IEC 62305-3



This method is based on an electrogeometric model that assumes that the last step of the downward leader can propagate in any direction. The model represents this with a sphere (of different radius depending on the required protection level) whose centre is the end of the lightning downward leader. This sphere is rolled along the external surface of the structure to be protected, so that the points in contact with the sphere are susceptible to get a lightning strike. According to the Standard IEC 62305-3, the rolling sphere radius depends on the protection level:

- Protection level I: $D = 20$ m
- Protection level II $D = 30$ m
- Protection level III $D = 45$ m
- Protection level IV $D = 60$ m

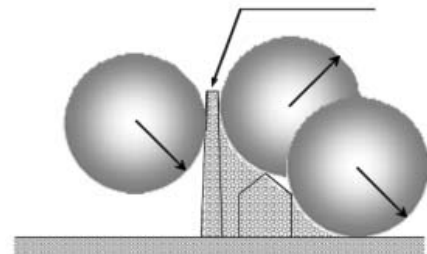

MESH METHOD FOR 60M HIGH RISE BUILDING AS PER IEC 62305-3

On structures lower than 60 m in height, generally flashes to the side may not occur, hence air-termination protection on sides will not be required.

On structures taller than 60 m, flashes to the side may occur, especially to points, corners and edges of surfaces. In general, the risk due to these flashes is low, but electrical and electronic equipment on walls or outside structures may be destroyed even by lightning flashes with low current peak values.

An air-termination system shall be installed to protect the upper part of tall structures (that is, typically the topmost 20 percent of the height of the structure as far as this part exceeds 60 m in height) and the equipment installed on it. The rules for positioning the air-termination systems on these upper parts of a structure shall meet at least the requirements for LPL IV with emphasis on the location of air-termination devices on corners, edges, and significant protrusions (such as balconies, viewing platforms, etc).

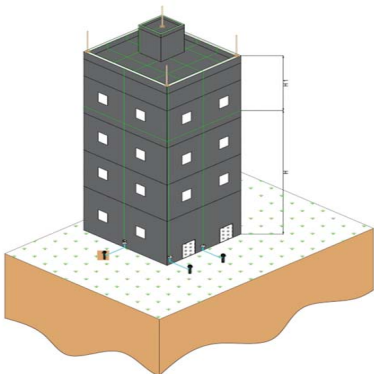

STRUCTURAL METHOD AS PER IEC 62305-3

BONDING NETWORK

A low impedance bonding network is needed to avoid dangerous potential differences between all equipment inside the building. Moreover, such a bonding network also reduces the magnetic field, thereby reduces the radiated surges inside the building and provides more protection for electrical/electronic equipment. This can be realized by a meshed bonding network integrating conductive parts of the structure, or parts of the internal systems, and by bonding metal parts or conductive services at the boundary of each LPZ directly or by using suitable SPDs. The bonding network can be arranged as a three-dimensional

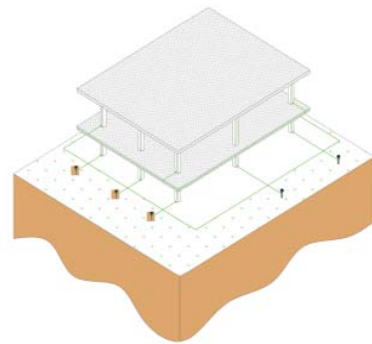

meshed structure with a typical mesh width of 5m. This requires multiple interconnections of metal components in and on the structure (such as concrete reinforcement, elevator rails, cranes, metal roofs, metal facades, metal frames of windows and doors, metal floor frames, service pipes and cable trays). Bonding bars (for example, ring bonding bars, several bonding bars at different levels of the structure) and

magnetic shields of the LPZ shall be integrated in the same way. Conductive parts (for example, cabinets, enclosures, racks) and the protective earth conductor (PE) of the internal systems shall be connected to the bonding network. Materials and Dimensions Copper and aluminium are recommended for exposed areas on installations required to have a long life. Galvanized steel may be preferred for temporary installations such as exhibition centres. Although it is a common practice to use material in the form of strip for horizontal air-terminations, down-conductors and bonds, it is more convenient to use round material, particularly as it facilitates the making of bends in any plane. If different materials are used in an installation, care should be taken to avoid galvanic corrosion by the use of bi-metallic connectors.

Lightning & the Need of Safety

Lightning is one of the most devastating natural phenomena. There are many discharges during lightning storms and some of them can even reach hundreds of kilo amperes. The electrical discharges are a great hazard to people, animal, buildings and electronic equipments. Until now, there is no device that can prevent lightning formation or lightning strikes. However, it is possible to create a path (divert) for the lightning discharge to the ground which will minimise the damage to the environment through a well designed Lightning Protection System (LPS). The purpose of a lightning protection system is to protect buildings from direct lightning strikes and possible fire or from the consequences of lightning

currents (non-igniting flash). If national regulations such as building regulations, special regulations or special directives require lightning protection measures, they must be implemented. If these regulations do not specify a class of LPS, a lightning protection system which meets the requirements of class of LPS III according to IEC 62305-3 (EN 62305-3) is recommended as a minimum. In principle, a risk analysis, which is described in the IEC 62305-2 (EN 62305-2) standard (see chapter 3.2.1), should be performed for an overall assessment.

Lightning Current and Protection levels

In order to define lightning as a source of interference, lightning protection levels I to IV are laid down. Each lightning protection level requires a set of

- Maximum values (dimensioning criteria used to design lightning protection components to meet the demands expected to be made of them)
- Minimum values (interception criteria necessary to be able to determine the areas with sufficient protection against direct lightning strikes (radius of rolling sphere).



Maximum values of lightning current parameters and their probabilities			
	Minimum values (Interception criteria)		
Lightning protection level	Minimum lightning current peak value	Probability of the actually upcoming lightning current to be higher than the minimum lightning current peak value	Radius of the rolling sphere
I	3 kA	99%	20 m
II	5 kA	97%	30 m
III	10 kA	91%	45 m
IV	16 kA	84%	60 m

Maximum values of lightning current parameters and their probabilities		
	Maximum values (Dimensioning criteria)	
Lightning protection level	Maximum lightning current peak value	Probability of the actually upcoming lightning current to be less than the maximum lightning current peak value
I	200 kA	99%
II	150 kA	98%
III	100 kA	97%
IV	100 kA	97%

Standard	Subject
IEC 62305 - 1 (EN 62305-1): 2010 - 12	Protection against lightning Part 1: General principles
IEC 62305 - 2 (EN 62305-2): 2010 - 12	Protection against lightning Part 2: Risk management
IEC 62305 - 3 (EN 62305-3): 2010 - 12	Protection against lightning Part 3: Physical damage to structures and life hazard
IEC 62305 - 4 (EN 62305-4): 2010 - 12	Protection against lightning Part 4: Electrical and electronic systems within structures

Class of LPS	Visual Inspection	Complete Inspection	Complete Inspection of Critical Situations
I and II	1 Year	2 Years	1 Year
III and IV	2 Years	4 Years	1 Year



Lightning protection systems utilised in applications involving structures with a risk caused by explosive materials should be visually inspected every 6 months. Electrical testing of the installation should be performed once a year. An acceptable exception to the yearly test

schedule would be to perform the tests on a 14 to 15 month cycle where it is considered beneficial to conduct earth resistance testing over

different times of the year to get an indication of seasonal variations.

Critical situations could include structures containing sensitive internal systems, office blocks, commercial buildings or places where a high number of people may be present

Part no. Description

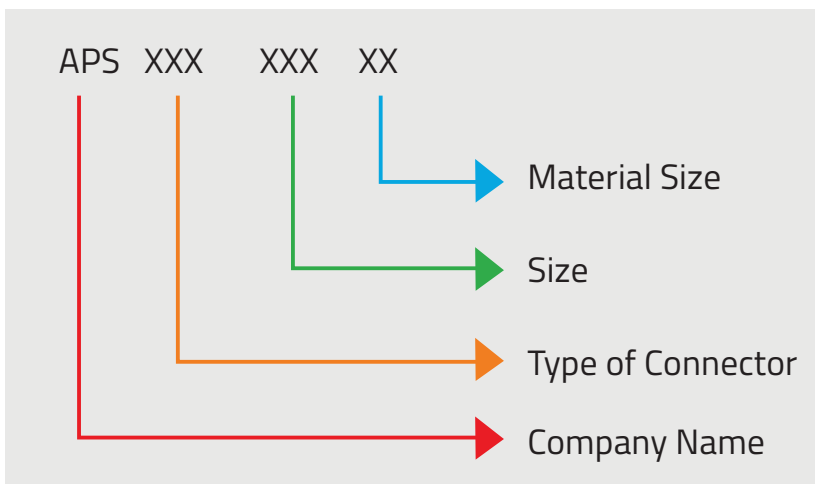

CONVENTIONAL
LIGHTNING PROTECTION
SPIKE AIR TERMINAL

COPPER AIR TERMINAL WITH SPIKE				
Rod Length	Rod Diameter	Thread Diameter	Material	Part No.
300mm	16/25mm	17/26 mm	Copper	APSFS 0316C
500mm	16/25mm	17/26 mm	Copper	APSFS 0516C
1000mm	16mm	17mm	Copper	APSFS 116C
2000mm	16mm	17mm	Copper	APSFS 216C
3000mm	16mm	17mm	Copper	APSFS 316C



COPPER AIR TERMINAL				
Rod Length	Rod Diameter	Thread Diameter	Material	Part No.
300mm	16/25mm	17/26mm	Copper	APS 0316C
500mm	16/25mm	17/26mm	Copper	APS 0516C
1000mm	16mm	17mm	Copper	APS 116C
2000mm	16mm	17mm	Copper	APS 216C
3000mm	16mm	17mm	Copper	APS 316C



ALUMINIUM AIR TERMINAL

Rod Length	Rod Diameter	Thread Diameter	Material	Part No.
300mm	16/25mm	17/26mm	Aluminium	APS 0316Al
500mm	16/25mm	17/26mm	Aluminium	APS 0516Al
1000mm	16mm	17mm	Aluminium	APS 116Al
2000mm	16mm	17mm	Aluminium	APS 216Al
3000mm	16mm	17mm	Aluminium	APS 316Al



GI AIR TERMINAL

Rod Length	Rod Diameter	Thread Diameter	Material	Part No.
300mm	25mm	26mm	GI	APS 325GI
500mm	25mm	26mm	GI	APS 525GI



CONVENTIONAL LIGHTNING
PROTECTION MATERIAL
GUNMETAL

AIR TERMINAL BASE

Rod Diameter	Thread Diameter	Maximum Conductor Size	Material	Part No.
10mm	11mm	25mm	Gun Metal	APSGTB 10-253
16mm	17mm	25mm	Gun Metal	APSGTB 16-253



GUN METAL CROSS CONNECTOR FOR TAPE

Conductor Size	Material	Part No.
25X3mm	Gun Metal	APSCCT 253
25X6mm	Gun Metal	APSCCT 256
50X6mm	Gun Metal	APSCCT 506

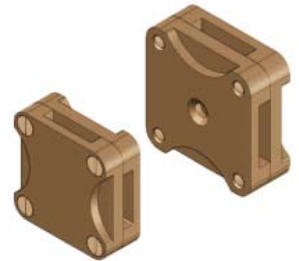

GUN METAL CROSS CONNECTOR FOR 8MM CONDUCTOR

Conductor Size	Conductor Size	Material	Part No.
50mm ²	8mm	Gun Metal	APSCCRC 50
70mm ²	10mm	Gun Metal	APSCCRC 70



GUN METAL PARALLEL CONNECTOR FOR 8MM CONDUCTOR

Conductor Size	Conductor Size	Material	Part No.
50mm ²	8mm	GUN METAL	APSPCRC 50
70mm ²	10mm	GUN METAL	APSPCRC 70

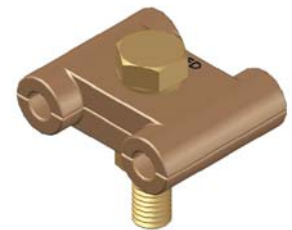

GUN METAL T-CONNECTOR FOR 8MM CONDUCTOR

Conductor Size	Conductor Size	Material	Part No.
50mm ²	8mm	GUN METAL	APSTCRC 50
70mm ²	10mm	GUN METAL	APSTCRC 70



GUN METAL HOLDER FOR 8MM CONDUCTOR ON VERTICAL

Tape Size	Material	Part No.
25X3mm	Gun Metal	APSTS253
25X6mm	Gun Metal	APSTS256
30X3mm	Gun Metal	APSTS303
50X6mm	Gun Metal	APSTS506



GUN METAL HOLDER FOR 8MM CONDUCTOR

Conductor Size	Material	Part No.
50 sqmm	GUN METAL	APSRCS50
70 sqmm	GUN METAL	APSRCS70



GUN METAL STRAIGHT CONNECTOR FOR TAPE

Tape Size	Material	Part No.
25X3mm	GUN METAL	APSSCT253
25X6mm	GUN METAL	APSSCT256
30X3mm	GUN METAL	APSSCT303
50X6mm	GUN METAL	APSSCT506

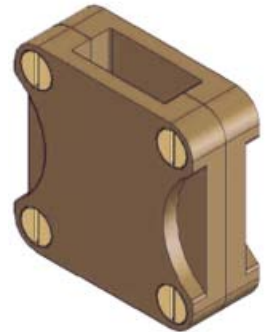

COUPLER FOR TAPE & ROUND CONDUCTOR

Tape Size	Conductor Size	Material	Part No.
25X3mm	50	GUN METAL	APSCTRC253-50
25X3mm	70	GUN METAL	APSCTRC253-70
25X6mm	50	GUN METAL	APSCTRC256-50
25X6mm	70	GUN METAL	APSCTRC256-70
30X3mm	50	GUN METAL	APSCTRC303-50
30X3mm	70	GUN METAL	APSCTRC303-70
50X6mm	50	GUN METAL	APSCTRC506-50
50X6mm	70	GUN METAL	APSCTRC506-70



CLAMP FOR EARTHING ROD

Rod Size	Material	Part No.
14.2mm	GUN METAL	APSERC14
17.2mm	GUN METAL	APSERC17
25.4mm	GUN METAL	APSERC25



CLAMP FOR CONNECTING EARTH ROD & TAPE

Rod Size	Tape Size	Material	Part No.
14.2-25	25X3mm	GUN METAL	APSCETC253
14.2-25	25X6mm	GUN METAL	APSCETC256
14.2-25	30X3mm	GUN METAL	APSCETC303
14.2-25	50X6mm	GUN METAL	APSCETC506



CLAMP FOR CONNECTING EARTH ROD & ROUND CONDUCTOR

Rod Size	Conductor Size	Material	Part No.
14.2-25.4	16- 185 sqmm	GUN METAL	APSCERC14-25

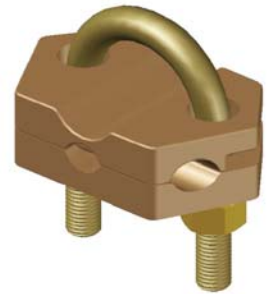

GUN METAL EARTH POINT

Description	Hole Size	Material	Length	Part No.
One Hole	M8X15mm	GUN METAL	75mm	APSEP1
Two Hole	M8X15mm	GUN METAL	75mm	APSEP2
Four Hole	M10X15mm	GUN METAL	75mm	APSEP4

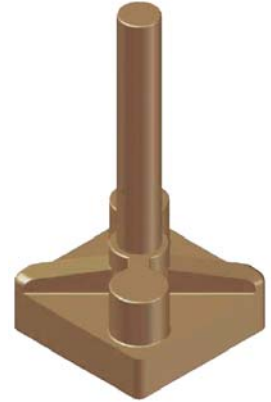

ROOF CONDUCTOR HOLDER FOR 8MM CONDUCTOR

Conductor Size	Material	Part No.
50 sqmm	GUN METAL	APSRCH50
70 sqmm	GUN METAL	APSRCH70



DOWN CONDUCTOR HOLDER FOR 8MM CONDUCTOR		
Conductor Size	Material	Part No.
50 sqmm	GUN METAL	APSRCH50
70 sqmm	GUN METAL	APSRCH70



COUPLER		
Thread Size	Material	Part No.
5/8"	GUN METAL	APSCC58
3/4"	GUN METAL	APSCC34



CONVENTIONAL LIGHTNING PROTECTION MATERIAL - SS

SS CROSS CONNECTOR FOR TAPE		
Tape Size	Material	Part No.
25X3mm	SS / AL	APSCCTSS25X3
25X6mm	SS / AL	APSCCTSS25X6
30X3mm	SS / AL	APSCCTSS30X3
50X6mm	SS / AL	APSCCTSS50X6



SS CONNECTOR FOR 8MM & TAPE			
Conductor Size	Tape Size	Material	Part No.
50/70 sqmm	25X3mm	SS / AL	APSPCSS253-8/10
50/70 sqmm	25X6mm	SS / AL	APSPCSS256-8/10
50/70 sqmm	30X3mm	SS / AL	APSPCSS303-8/10
50/70 sqmm	50X6mm	SS / AL	APSPCSS506-8/10



SS PARALLEL CONNECTOR FOR 8MM CONDUCTOR

Conductor Size	Conductor Size	Material	Part No.
50mm ²	8mm	SS/AL	APSPCRC 50
70mm ²	10mm	SS/AL	APSPCRC 70

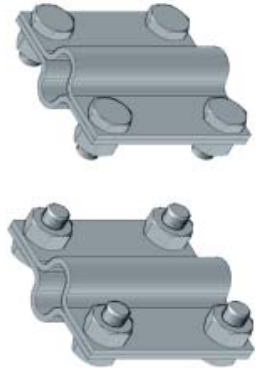

SS HOLDER FOR TAPE

Tape Size	Material	Part No.
25X3mm	SS / AL	APSTSSS25X3
25X6mm	SS / AL	APSTSSS25X6
30X3mm	SS / AL	APSTSSS30X3
50X6mm	SS / AL	APSTSSS50X6



SS HOLDER FOR 8MM DOWN CONDUCTOR

Conductor Size	Material	Part No.
50 sqmm	SS / AL	APSDCHSS50
70 sqmm	SS / AL	APSDCHSS70



SS HOLDER FOR 8MM CONDUCTOR ON SHEET

Conductor Size	Material	Part No.
50 sqmm	SS / AL	APSSCHSS50
70 sqmm	SS / AL	APSSCHSS70

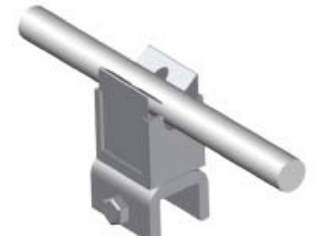

SS HOLDER FOR 8MM CONDUCTOR ON ROOF

Conductor Size	Material	Part No.
50 sqmm	SS / AL	APSRCHSS50
70 sqmm	SS / AL	APSRCHSS70



AIR TERMINAL SS BASE

Rod Diameter	Thread Diameter	Maximum Conductor Size	Material	Part No.
10mm	11mm	25mm	SS	APSSSTB 10-253
16mm	17mm	25mm	SS	APSSSTB 16-253



SS CROSS-CONNECTOR FOR 8MM CONDUCTOR

Conductor Size	Material	Part No.
50 sqmm	SS / AL	APSCCTSS50
70 sqmm	SS / AL	APSCCTSS70



CONVENTIONAL LIGHTNING PROTECTION CLAMPING MATERIAL

SIDE WALL CLAMP FOR STEEL GIRDERS		
Air Terminal Size	Material	Part No.
18-30mm	SS	APSSWGGI
18-30mm	SS	APSSWGAL
18-30mm	SS	APSSWGSS



SIDE WALL CLAMP FOR AIR TERMINAL			
Hole dia	Holder Length	Material	Part No.
44mm	230mm	GI / SS	APSSWC40
16mm	150mm	GI / SS	APSSWC16
10mm	150mm	GI / SS	APSSWC10



CONVENTIONAL LIGHTNING PROTECTION CONDUCTOR

8MM ALUMINIUM CONDUCTOR

Conductor Size	Material	Part No.
50 sqmm	ALUMINIUM	APSA18
70 sqmm	ALUMINIUM	APSA10



GI STRIP

Tape Size	Material	Part No.
25X3mm	GI	APSGI253
25x6mm	GI	APSGI256
50x6mm	GI	APSGI506



SS STRIP

Tape Size	Material	Part No.
25X3mm	SS	APSSS253
25x6mm	SS	APSSS256



COPPER STRIP		
Tape Size	Material	Part No.
25X3mm	COPPER	APSCU253
25x6mm	COPPER	APSCU256
30X3mm	COPPER	APSCU303

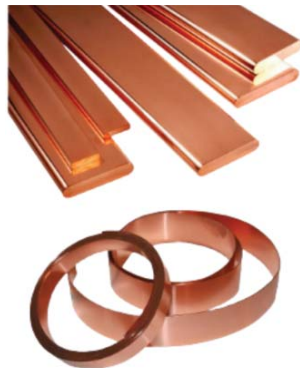

10MM COPPER BONDED CONDUCTOR		
Conductor Size	Material	Part No.
70 sqmm	MS WITH COPPER COATING	APS10



10MM COPPER BONDED FLEXIBLE CONDUCTOR		
Conductor Size	Material	Part No.
70 sqmm	MS WITH COPPER COATING	APS10



TEST LINK WITH BOX		
Tape Size	Material	Part No.
As per requirement	CU	APSTLBCU
As per requirement	GI	APSTLBGI

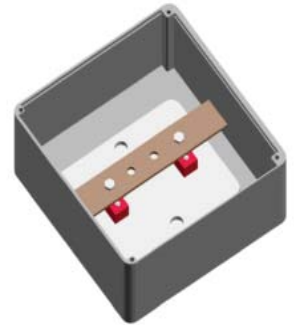

TEST LINK WITHOUT BOX		
Tape Size	Material	Part No.
As per requirement	CU	APSTLCU
As per requirement	GI	APSTLGI

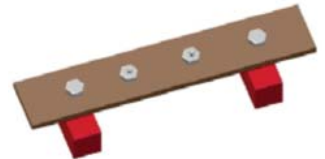

ALUMINIUM STRAIGHT CONNECTOR WITH SS BOLT

Conductor Size	Material	Part No.
50 sqmm	ALUMINIUM	APSCEPAL50
70 sqmm	ALUMINIUM	APSCEPAL70



EXPANSION JOINT WITH CONNECTOR

Conductor Size	Material	Part No.
50 sqmm	ALUMINIUM	APSEXP50
70 sqmm	ALUMINIUM	APSEXP70

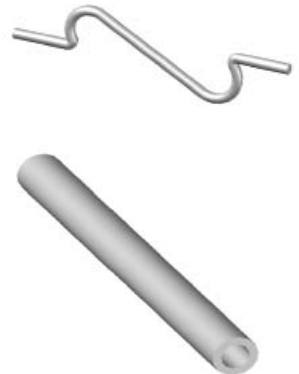

KS CONNECTOR		
Conductor Size	Material	Part No.
50 sqmm	SS	APSK50
70 sqmm	SS	APSK50



BRIDGING CABLE		
Size	Material	Part No.
25 x 3 mm	Copper	APSBC253
25 x 6 mm	Copper	APSBC256



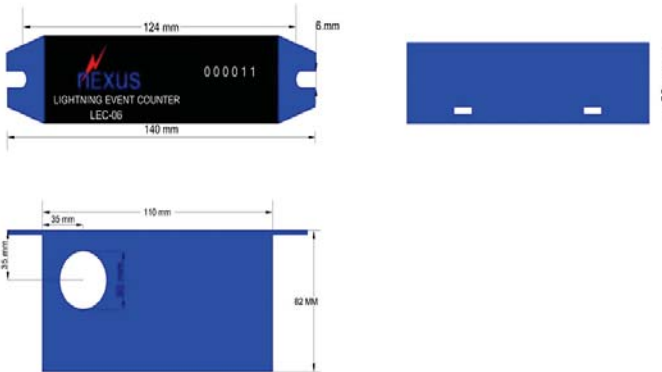

NEXUS Lightning Event Counter (LEC-06) is a device to be inserted to the down conductor to register the lightning strikes. It allows the automatic counting of the strikes received by the lightning protection system.

The LEC-06 is simply mounted at any location along the down conductor route. Its purpose is to record the number of strikes captured by the lightning terminal and conveyed by the down conductor. Using a non-intrusive inductive pickup, the counter will accurately record a lightning event for later reference.

The LEC-06 operates by sensing current by means of an inductive pick up loop. The loop

passes along the inside surface of the bottom of the enclosure. With the voltage impulse detected by the current transformer (CT) a trigger to the pulse counter then turns the counter to register the event.

The Lightning Event Counter (LEC-06) can be installed at any location on the down conductor route between the air terminal and the earthing system. Long service life, no battery needed and maintenance free. Sensitive response and wide lightning current measuring range. Can be used together with all kinds of lightning protectors and equipment. Record surge or lightning event from trigger threshold of 250A.



LIGHT EVENT COUNTER

LEC 06

FEATURES

- Ease of installation, LEC-06 can be retro-fitted to any lightning protection system.
- IP 67 rated enclosure suitable for external application.
- Non resettable electro-mechanical counter.
- Non-intrusive and fast acting proximity circuit detects lightning transient currents.
- Can be mounted at any location along the down conductor.

MODEL	LEC-06
Description	Lightning Event Counter
Current sensitivity (8/20 js)	> 250A
Display Model	Electromechanical display (non re-settable)
Indicator	6 digit Lightning Event 0~999999
Current Sample Mode	Inductive Probe (Built-in)
Operating temperature (°C)	-20 ~ +85
Dimension of window (mm)	32
Dimension of counter (mm)	140 x82. x32
Enclosure material	Steel
Degree of protection	IP 67 (IEC 529)

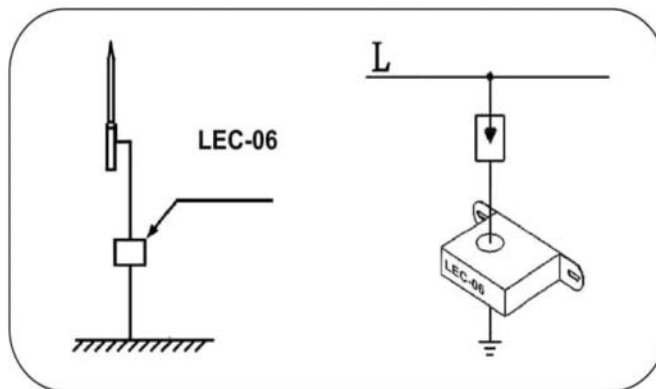

Product Description

Features

7 Digits

Up to 9,999,999 counts

Testable using LSR-Tester

LPI® Lightning Strike Recorder (LSR2) is a lightning event counter. The LSR2 is simply mounted at any location along the down-conductor route. Its purpose is to record the number of strikes captured by the lightning air terminal and conveyed by the down-conductor.

The LSR2 operates by sensing current by means of an inductive pick up loop. The loop passes along the inside surface of the bottom of the enclosure. This loop detects lightning current impulses on the down-conductor and sends a trigger to the counter, which turns the counter over to register the event. The Recorder is mounted in a polycarbonate enclosure rated IP 67.



Installation/ Operating Instruction

The Lightning Strike Recorder (LSR2) can be installed at any location on the down-conductor route between the air terminal and the earthing system.

The LSR should be mounted in line with the down-conductor as shown in Figure 1. If using flat down-conductor use the plastic spacer provided, as per Figure 2. To remove or relocate the LSR, use a small flat bladed screwdriver to release the clip on the latching mechanism on the cable tie.

PRODUCT CODE: LSR2

Description	Lightning Strike Recorder
Current Sensitivity	1500A 8/20 μ s
Operating Range	Min. 1500A, 8/20 μ sMax. 220kA, 8/20 μ s
Display	Mechanical 7 digits display(non-resettable)
Dimensions	100mm (L) x 100mm (H) x 55mm(D)
Weight	0.56 kg
Mounting	Releasable UV resistant plasticcable ties Suitable for up to $\text{Æ}40$ mm cable or 50 x 5mm flat tape
Construction	Polycarbonate Enclosure
Colour	Light Grey
Environment	IP 67 (IEC 529)
Working Temperature	-15°C to 65°C



SURGE MINI HAND-BOOK

General distribution of lightning current when an object is thunderstruck, principle of LV power system protection thanks to cascaded 3-stage protection

Protection system of LV power system composed of lightning current arresters and surge arresters SPD must be able to discharge lightning currents or their substantial parts without their damage. It is generally recommended to come out from the ohmic resistance of the building earthing, pipeline, power distribution system and so on for the purposes of establishing current distribution going through SPD in case of direct lightning stroke into a building protected by the outside lighting system. The following figure shows a typical example of lightning current distribution in an object hit by direct lightning stroke. Where an individual evaluation is not possible, it can be assumed that:

- 50% of the total lightning current $I_{mp} = 200kA$ (10/350)....

$I_{s1} = 100kA$ (10/350) enters the earth termination system of the LPS (lightning protection system) of the structure considered

- 50% of $I_{mp} = 200kA$ (10/350) $I_{s2} = 100kA$ (10/350) is distributed among the services entering the structure (external conductive parts, el.power, communication lines, etc.) The value of the current flowing in each service I_i is given by I_i/n , where n is the number of the above mentioned services (see the above figure)

For evaluating the current I_i in individual conductors in unscreened cables, the cable current I_i is divided by m , the number of conductors, i.e. $I_i = I_i/m$.

For shielded cables, the current will flow along the shield. Requirement on dimensioning of protective system SPD in the most usual connection of the building and LV power system (TNC - system 230/400V/50Hz) results from this reasoning:

For maximum lightning current size $I_{mp} = 200kA$ (10/350) it is enough to dimension the protective cascade of each phase conductor entering the object on approx. 4% I_{mp} that is on approx. 8kA (10/350) in most cases.

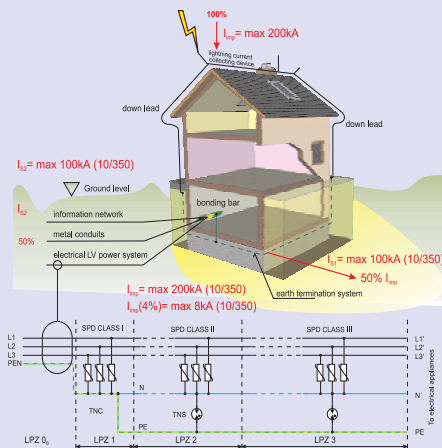

Distribution of protected area into the lightning protection zones

The standard IEC 13 12-1 and IEC 62 305 defines the lightning protection zones LPZ from the respect of the direct even indirect lightning effect. These zones are characteristic thanks to fundamental breaks of the electromagnetic conditions in their limited zones.

LPZ 0:

Zone where items are subject to direct lightning strokes, and therefore may have to carry up to the full lightning current; the unattenuated electromagnetic field occurs here.

LPZ 0_s:

Zone where items are not subject to direct lightning strokes, but the unattenuated electromagnetic field occurs.

LPZ 1:

Zone where items are not subject to direct lightning strokes and where currents on all conductive parts within this zone are further reduced compared with zones 0_s. In this zone the electromagnetic field may also be attenuated depending on the screening measure.

The subsequent zones (LPZ 2 and so on):

If a further reduction of conducted currents and/or electromagnetic field is required, subsequent zones shall be introduced. The requirement for those zones shall be selected according to the required environmental zones of the system to be protected. In general, the higher the number of the zones, the lower the electromagnetic environment parameters. At the boundary of the individual zones, bonding of all metal penetrations shall be provided and screening measures might be installed.

Note: Bonding at the boundary between LPZ0_s, LPZ0, and LPZ 1 is defined in IEC 13 12-1 AND IEC 62 305. The electromagnetic fields inside a structure are influenced by opening windows, by currents on metal conductors (e.g. bonding bars, cable shields and tubes), and by cable routing.

The following figure shows an example for dividing a structure into several zones. There all electric power and signal lines enter the protected volume (LPZ 1) at one point, and are bonded to bonding bar 1 at the boundary of LPZ 0_s, LPZ 0_s, and LPZ 1. In addition, the lines are bonded to the internal bonding bar 2 at the boundary of LPZ 1 and LPZ 2. Furthermore, the outer shield 1 of the structure is bonded to bonding bar 1 and the inner shield 2 to bonding bar 2. Where cables pass from one LPZ to another, the bonding must be executed at each boundary. LPZ 2 is constructed in such a way that partial lightning currents are not transferred into this volume and cannot pass through it.

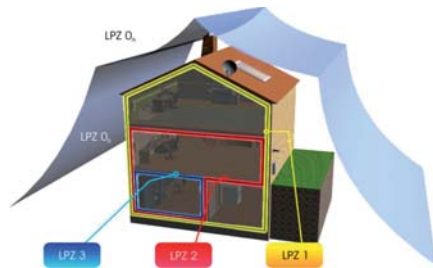

The above described segmentation of the protected object into protection zones gives possibilities of active protection of the LV power system thanks to insertion of the protective SPDs (usually at the zone boundary LPZ0 → 1 and LPZ1 → 2) and other protective SPDs at the zone boundary LPZ → 3. Standardly it is recommended to insert so-called 1st stage protection - surge arrester class I tested by lightning current I_{mp} (10/350) at the zone boundary LPZ 0 → 1. It is recommended to insert 2nd stage protection - surge arrester class II tested by testing impulse I_{max} (8/20) at the boundary zone LPZ1 → 2. At the boundary of LPZ 2 → 3 and subsequently along the consequential circuit there is also recommended to shoulder after every cca 10m by so-called 3rd stage protection class III also tested by testing impulse I_{max} (8/20) or U_{oc} . For extra important protected equipment it is recommended to secure it by a quality continuous surge protection class III with high-frequency filter at the boundary of LPZ 2 → 3. If there are adjacent structures between which power and communication cables pass, the earthing system shall be interconnected, and it is beneficial to have many parallel paths to reduce current in the cables. A meshed earthing system fulfills this requirement. The lightning currents are further reduced, e.g. by enclosing all the cables in metal conduits of gridlike reinforced concrete ducts, which must be integrated into the meshed earthing system.

SURGE PROTECTION DEVICE

TYPE 1 / CLASS I

TYPE HS50 - 50i HS50-50i 50i LED



Type		HS50-50i	HS50-50i LED
Test class according to EN 61643-11 ed.2 and IEC 61643-1			TYPE 1, CLASS I
Nominal Voltage	U_N		230 V
Max. continuous operating voltage	U_C		320 V AC
Lightning impulse current (10/350)	I_{imp}		50 kA
- charge	Q		25 As
- specific energy	W/R		600 kJ/Ω
Nominal discharge current (8/20)	I_n		50 kA
Voltage protection level at I_{imp}	U_p		< 1.3 kV
Temporary overvoltage (TOV)	U_T		425 V/5 s
Response time	t_A		< 100 ns
Follow current extinguishing capacity at U_C	I_n		25 kA _{rms}
Max. back-up fuse			500 AgL/gG
Short-circuit withstand capability at max. back-up fuse	I_p		25 kA _{rms}
LPZ			0-1
Housing material			Polyamid PA6, UL94 V-0
Protection type			IP20
Operating temperature range	J		-40°C ... +80 °C
Cross-section of the connected conductors (at tightening moment of clamps 4 Nm)			10 - 35 mm ² (solid) 10 - 25 mm ² (flexible) 10 - 25 mm ² (multi-wire)
Mounting on			DIN rail 35 mm
Operating Indication (LED)			Green-Ok/Red-Fault
Weight	m	225	230
Article number		10 091	10 591



TYPE 1 / CLASS I / TN-S / TT /



HS100

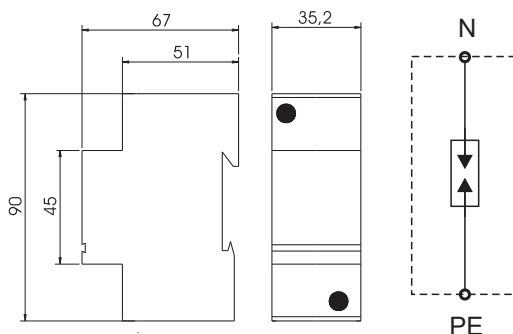

HS100 is the total current spark gaps type 1 according to EN 61643-11 and IEC 61643-1. These are recommended for use in the Lightning Zones Concept at the boundaries of LPZ 0 - 1 (according to IEC 1312-1 and EN 62305), where they provide the equipotential bonding and discharge of both, the lightning current and the switching surge, which are generated in power supply systems entering the building. The lightning arresters are constructed as the encapsulated, non-exhaust, multiple spark gaps, which do not have any special requirements for installation in the main switchboards in terms of the gas exhaustion generated during the passage of the lightning current. They are intended for use in TN-S and TT systems. HS100 and JK110 are to be installed only between N and PE in modifications of 3+1 or 1+1.

Type		HS100
Test class according to EN 61643-11 ed.2 and IEC 61643-1		TYPE 1, CLASS I
Max. continuous operating voltage	U_C	255 V AC
Lightning impulse current (10/350)	I_{imp}	100 kA
- charge	Q	50 As
- specific energy	W/R	2500 kJ/Ω
Nominal discharge current (8/20)	I_n	75 kA
Voltage protection level at I_{imp}	U_P	< 2 kV
Temporary overvoltage (TOV)	U_T	1200 V / 0.2 s
Response time	t_A	< 100 ns
Follow current interrupting rating at U_C	I_{fi}	100 A _{rms}
LPZ		0-1
Housing material		Polyamid PA6, UL94 V-0
Protection type		IP20
Operating temperature range	θ	-40°C ... +80 °C
Cross-section of the connected conductors (at tightening moment of clamps 4 Nm)		35 mm ² (solid) 25 mm ² (wire)
Mounting on		DIN rail 35 mm
Weight	m	360 g
Article number		10 200



Surge Arrester

TYPE 2 / CLASS II

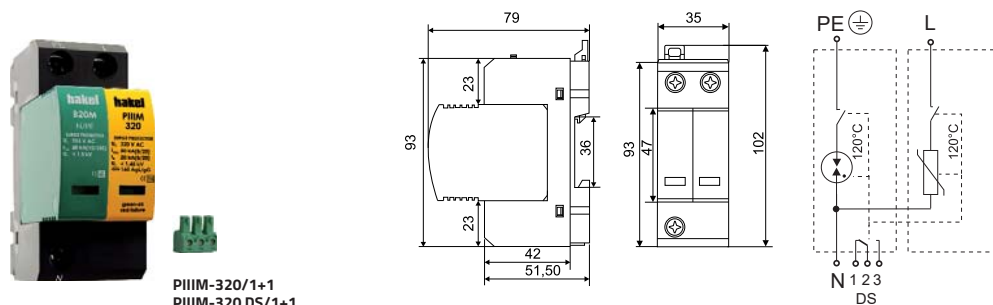

PIIIM-320/1+1 V series is a two-pole, metal oxide varistor surge arrester combined with gas discharge tube, Type 2 & Class II according to EN 61643-11 and IEC 61643-1. These arresters are recommended for use in the Lightning Protection Zones Concept at the boundaries of LPZ 1-2 (according to IEC 1312-1 and EN 62305), where they provide the equipotential bonding and discharge of the switching overvoltage, which is generated in power supply systems entering the building. The main use of PIIIM-320/1+1 V series arrester is in all kinds of industry, residential and administration buildings. They are to be placed into the subsidiary switchboards or control boxes. The marking **M** specifies a type of construction with removable module. The marking **DS** specifies a version with remote monitoring.

Type	PIIIM-320/1+1, PIIIM-320 DS/1+1	
Test class according to EN 61643-11 ed.2 and IEC 61643-1	TYPE 2, CLASS II	
Max. continuous operating voltage	U_c	320 V AC / 420 V DC
Max. discharge current (8/20)	I_{max}	50 kA
Nominal discharge current (8/20) L/N	I_n	20 kA
Nominal discharge current (8/20) N/PE	I_n	20 kA
Voltage protection level	U_p	< 1.45 kV
Lightning impulse current (10/350) N/PE	I_{imp}	20 kA
Temporary overvoltage (TOV) L/N	U_T	335 V/5 s
Temporary overvoltage (TOV) N/PE	U_T	1200 V/0.2 s
Response time L/N	t_A	< 25 ns
Response time N/PE	t_A	< 100 ns
Max. back-up fuse		160 AgL/gG
Short-circuit withstand capability	I_p	60 kA _{rms}
LPZ		1-2
Housing material		Polyamid PA6, UL94 V-0
Protection type		IP20
Operating temperature range	J	-40 °C ... +80 °C
Cross-section of the connected conductors (at tightening moment of clamps 4 Nm)		2.5 - 25 mm ² (solid) 2.5 - 16 mm ² (flexible) 2.5 - 16 mm ² (multi-wire)
Mounting on		DIN rail 35 mm
Failure indication		green - ok / red - failure
Potential free signal contact (DS) (recommended cross-section of remote monitoring max.1 mm ²)		AC: 250 V / 0.5 A, DC: 250 V / 0.1 A
Weight	m	166 g
Article number		
PIIIM-320/1+1		27 018
PIIIM-320 DS/1+1		27 019
Varistor-based spare module		
PIIIM-320/M		27 045
GDT spare module		
B20M/M		27 049



Surge Arrester

TYPE 2 / CLASS II



PIIM-320/3+1
PIIM-320 DS/3+1

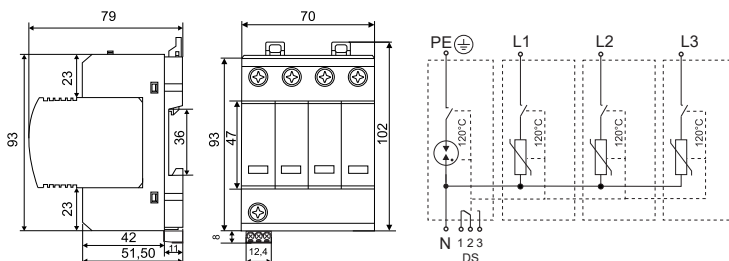

PIIM-320/3+1 V series is a four-pole, metal oxide varistor surge arrester combined with gas discharge tube, Type 2 & Class II according to EN 61643-11 and IEC 61643-1. These arresters are recommended for use in the Lightning Protection Zones Concept at the boundaries of LPZ 1-2 (according to IEC 1312-1 and EN 62305), where they provide the equipotential bonding and discharge of the switching overvoltage, which is generated in power supply systems entering the building. The main use of PIIM-320/3+1 V series arrester is in all kinds of industry, residential and administration buildings. They are to be placed into the subsidiary switchboards or control boxes. The marking **M** specifies a type of construction with removable module. The marking of **DS** specifies a version with remote monitoring.

Type		PIIM-320/3+1, PIIM-320 DS/3+1
Test class according to EN 61643-11 ed.2 and IEC 61643-1		TYPE 2, CLASS II
Max. continuous operating voltage	U_c	320 V AC / 420 V DC
Max. discharge current (8/20)	I_{max}	50 kA
Nominal discharge current (8/20) L/N	I_n	20 kA
Nominal discharge current (8/20) N/PE	I_{n1}	20 kA
Voltage protection level	U_p	< 1.45 kV
Lightning impulse current (10/350) N/PE	I_{imp}	20 kA
Temporary overvoltage (TOV) L/N	U_T	335 V/5 s
Temporary overvoltage (TOV) N/PE	U_{T1}	1200 V/0.2 s
Response time L/N	t_A	< 25 ns
Response time N/PE	t_{A1}	< 100 ns
Max. back-up fuse		160 AgL/gG
Short-circuit withstand capability	I_p	60 kA _{rms}
LPZ		1-2
Housing material		Polyamid PA6, UL94 V-0
Protection type		IP20
Operating temperature range	J	-40°C ... +80 °C
Cross-section of the connected conductors (at tightening moment of clamps 4 Nm)		2.5 - 25 mm ² (solid) 2.5 - 16 mm ² (flexible) 2.5 - 16 mm ² (multi-wire)
Mounting on		DIN rail 35 mm
Failure indication		green - ok / red - failure
Potential free signal contact (DS) (recommended cross-section of remote monitoring max. 1 mm ²)		AC: 250 V / 0.5 A, DC: 250 V / 0.1 A
Weight	m	346 g
Article number		
PIIM-320/3+1		27 026
PIIM-320 DS/3+1		27 027
Varistor-based spare module		
PIIM-320/M		27 045
GDT spare module		
B20M/M		27 049

Lightning and surge arrester / varistor / TYPE 1+2

TYPE 1+2 / CLASS I+II / TN-S / CE

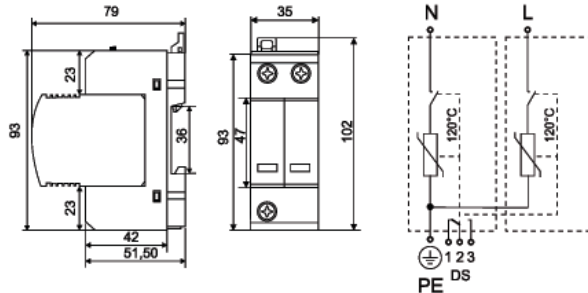

PIVM12.5-275/2+0
PIVM12.5-275 DS/2+0

PIVM12.5-275/2+0 γ series is a two-pole lightning and surge arrester Type 1+2 according to EN 61643-11 and IEC 61643-1. These arresters are recommended for use in the Lightning Protection Zones Concept at the boundaries of LPZ 0 – 1 (according to IEC 1312-1 and EN 62305), where they provide the equipotential bonding and discharge of both, the lightning current and the switching surge, which are generated in power supply systems entering the building. The use of the lightning current arresters PIVM12.5-275/2+0 γ series is mainly in the power supply lines, which are operated as TN-S system. The main use of PIVM12.5-275/2+0 γ series arrester is in structures of LPL III – IV according to EN 62305 ed.2.

The marking **M** specifies a type of construction with removable module. The marking of **DS** specifies a version with remote monitoring.

Type γ series		PIVM12.5-275/2+0, PIVM12.5-275 DS/2+0
Test class according to EN 61643-11 ed.2 and IEC 61643-1		TYPE 1+2, CLASS I+II
Max. continuous operating voltage	U_c	275 V AC / 350 V DC
Max. discharge current (8/20)	I_{max}	50 kA
Lightning impulse current (10/350)	I_{imp}	12.5 kA
- charge	Q	6.25 As
- specific energy	W/R	39 kJ/ Ω
Total lightning current (10/350) L1+N→PE	I_{total}	25 kA
Nominal discharge current (8/20)	I_n	20 kA
Voltage protection level	U_p	< 1,2 kV
Temporary overvoltage (TOV)	U_T	335 V/5 s
Response time	t_A	< 25 ns
Max. back-up fuse		160 AgL/gG
Short-circuit withstand capability	I_b	60 kA _{ms}
LPZ		0-1
Housing material		Polyamid PA6, UL94 V-0
Protection type		IP20
Operating temperature range	θ	-40°C ... +80 °C
Cross-section of the connected conductors (at tightening moment of clamps 4 Nm)		25 mm ² (solid) 16 mm ² (wire)
Mounting on		DIN rail 35 mm
Failure signalisation		green - ok / red - failure
Potential free signal contact (DS) (recommended cross-section of remote monitoring max.1 mm ²)		AC: 250 V / 0,5 A, DC: 250 V / 0,1 A
Lifetime		min.100 000 h
Weight	m	280 g
Article number		
PIVM12.5-275/2+0		16 050
PIVM12.5-275 DS/2+0		16 051
Varistor-based spare module		PIVM12.5-275/M 16 058



Lightning and surge arrester / varistor + gas discharge tube / TYPE 1+2

TYPE 1+2 / CLASS I+II / TN-S / TT / CE

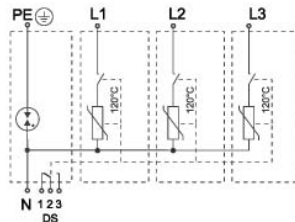
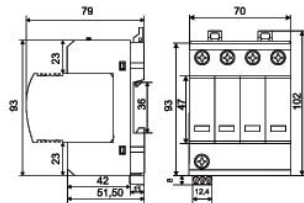

PIVM12.5-275/3+1 PIVM12.5-275 DS/3+1

PIVM12.5-275/3+1 **γseries** is a four-pole, metal oxid varistor lightning and surge arrester, combined with gas discharge tube Type 1+2 according to EN 61643-11 and IEC 61643-1. These arresters are recommended for use in the Lightning Protection Zones Concept at the boundaries of LPZ 0 – 1 (according to IEC 1312-1 and EN 62305 ed.2), where they provide the equipotential bonding and discharge of both, the lightning current and the switching surge, which are generated in power supply systems entering the building. The use of the lightning current arresters PIVM12.5-275/3+1 **γseries** is mainly in the power supply lines, which are operated as TN-S and TT systems. The main use of PIVM12.5-275/3+1 **γseries** arrester is in structures of LPL III – IV according to EN 62305 ed.2.

The marking **M** specifies a type of construction with removable module. The marking of **DS** specifies a version with remote monitoring.

Type γseries	PIVM12.5-275/3+1, PIVM12.5-275 DS/3+1	
Test class according to EN 61643-11 ed.2 and IEC 61643-1	TYPE 1+2, CLASS I+II	
Max. continuous operating voltage	U_c	275 V AC / 350 V DC
Max. discharge current (8/20)	I_{max}	50 kA
Lightning impulse current (10/350) L/N	I_{imp}	12.5 kA
- charge	Q	6.25 As
- specific energy	W/R	39 kJ/Ω
Lightning impulse current (10/350) N/PE	I_{imp}	50 kA
- charge	Q	25 As
- specific energy	W/R	625 kJ/Ω
Total lightning current (10/350) L1+L2+L3+N→PE	I_{total}	50 kA
Nominal discharge current (8/20)	I_n	20 kA
Voltage protection level	U_p	< 1.2 kV
Temporary overvoltage (TOV) L/N	U_T	335 V/5 s
Temporary overvoltage (TOV) N/PE	U_T	1200 V/0.2 s
Response time L/N	t_A	< 25 ns
Response time N/PE	t_A	< 100 ns
Max. back-up fuse		160 AgL/gG
Short-circuit withstand capability	I_p	60 kA _{rms}
LPZ		0-1
Housing material		Polyamid PA6, UL94 V-0
Protection type		IP20
Operating temperature range	θ	-40°C ... +80 °C
Cross-section of the connected conductors (at tightening moment of clamps 4 Nm)		25 mm ² (solid) 16 mm ² (wire)
Mounting on		DIN rail 35 mm
Failure signalisation		green - ok / red - failure
Potential free signal contact (DS) (recommended cross-section of remote monitoring max.1 mm ²)		AC: 250 V / 0.5 A, DC: 250 V / 0.1 A
Lifetime		min.100 000 h
Weight	m	536 g
Article number		
PIVM12.5-275/3+1		16 054
PIVM12.5-275 DS/3+1		16 055
Varistor-based spare module		PIVM12.5-275/M 16 058
GDT spare module		B50M/M 16 060

EARTH SEAL FOR RAFTING

The Dissipative Earth Seal is fitted when the earth rod connection is below the water level and where there is a possibility of water entering the inspection housing from below ground. APS earth seals are specifically designed to suit earth Rods of Various diameters from 1/2" to 3/4". These seals are used along with APS Earth Pits. Prevents the ingress of ground water into and surrounding the inspection housing. Waterproofing is achieved by enclosing an upper section of copper – bonded ground rod within a plastic pipe with seals located on both sides of the concrete pour. The two

plate-style flange serves to reduce pressure, which may occur from the capillary effect of water on the

outside of the seal and inspection housing.

The flanges are intended to prevent water pressure from "popping" the inspection pit out of the concrete. Delivered as a Earth Seals, including a 3.3 foot (1.0 meter) for double seal & 1.0 foot (0.30 meter) for Single seal PVC pipe, to be adjusted to site conditions.



EXOTHERMIC WELDING

PHASE - I

- This work will be carried out as per the approved specifications with consideration of all standards.
- Mat must be designed & constructed with IEEE recommended guidelines.
- Earth mat shall comprise with the dimensions required at site as per drawings.
- The mat is considered at 500 mm depth or below the base slab.

REFERENCE AND STANDARDS

- Provide the earth mat system in accordance with IEEE 80 & BS 7430
- All electrical installations shall be carried out in accordance with the best International Standards
- All Relevant approved documents, drawings & materials.

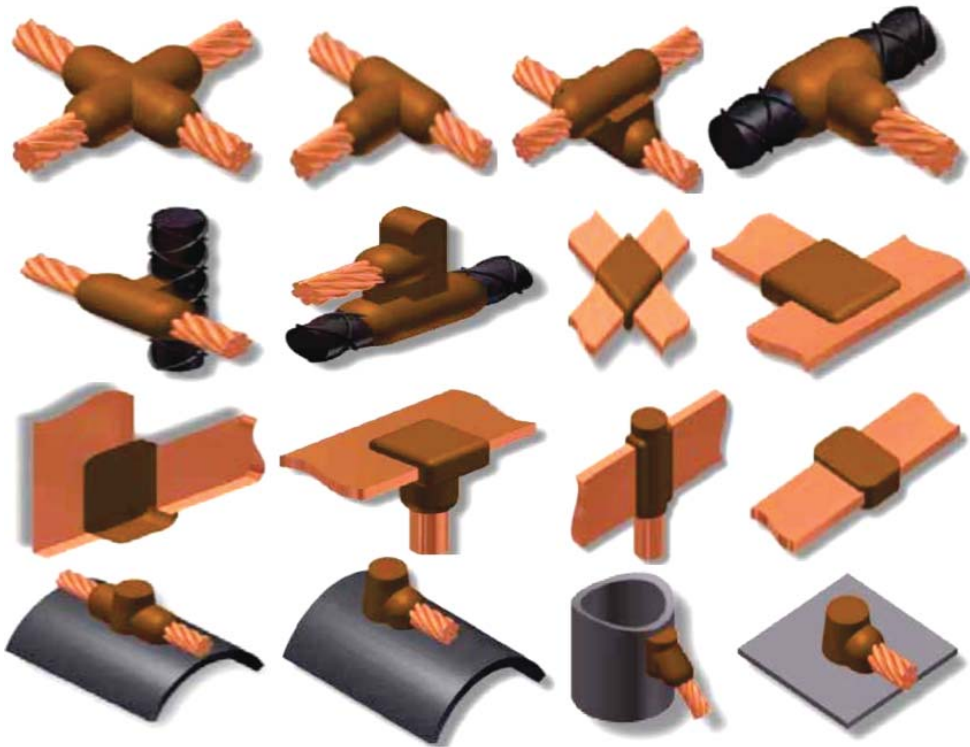

EARTHING

JK CHEMRODE MODEL NO – JK 314 CBR

Advance chemical gel earthing system for the proper dissipation of fault / leakage current to the ground and ensure the continuous electrical connectivity and proper functioning to the electrical system. The earth rod shall be of UL listed & CPRI tested 3 mtr long 14.2 mm dia 250 microns copper bonded steel rod along with 25 Kgs of JK RESLOW Resistance Lowering Grounding Minerals. The chemical compound should be tested and certified by any International accredited and BIS (Bureau of Indian Standards) accredited laboratory. The testing laboratory should be ISO 9001 & ISO 14001 certified. The UL listed copper bonded rod also should be tested & certified from CPRI for a short circuit current of 31.5 KA or more. The UL listing shall be punched / engraved on the rod for the physical verification at site.

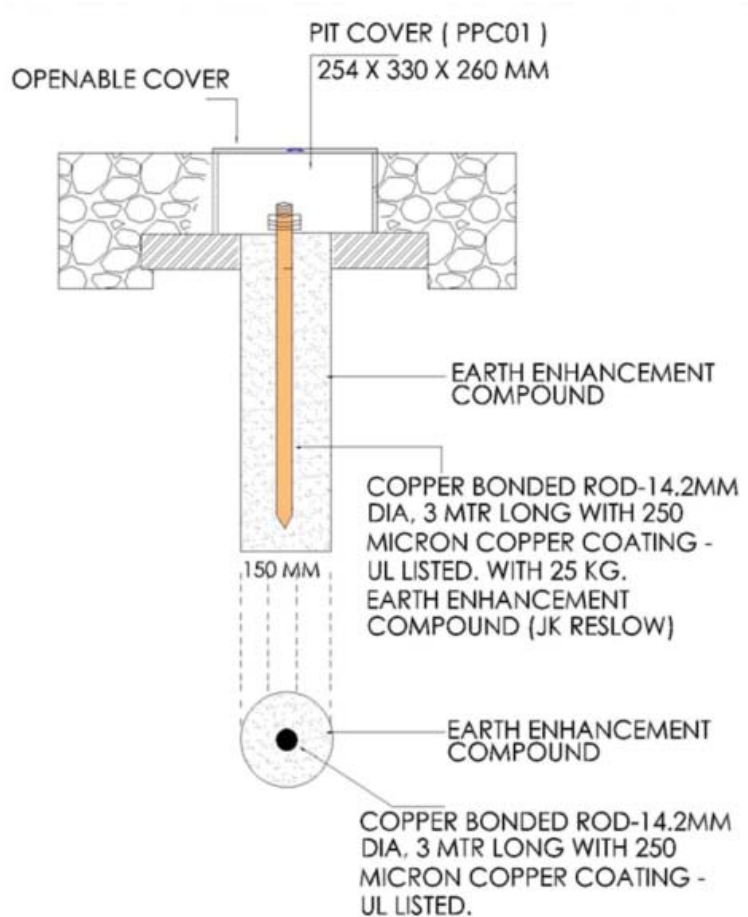

MODEL NO – JK 317 CBR

Advance chemical gel earthing system for the proper dissipation of fault / leakage current to the ground and ensure the continuous electrical connectivity and proper functioning to the electrical system. The earth rod shall be of UL listed & CPRI tested 3 mtr long 17.2 mm dia 250 microns copper bonded steel rod along with 25 Kgs of JK RESLOW Resistance Lowering Grounding Minerals. The chemical compound should be tested and certified by any International accredited and BIS (Bureau of Indian Standards) accredited laboratory. The testing laboratory should be ISO 9001 & ISO 14001 certified. The UL listed copper bonded rod also should be tested & certified from CPRI for a short circuit current of 46 KA or more. The UL listing shall be punched / engraved on the rod for the physical verification at site

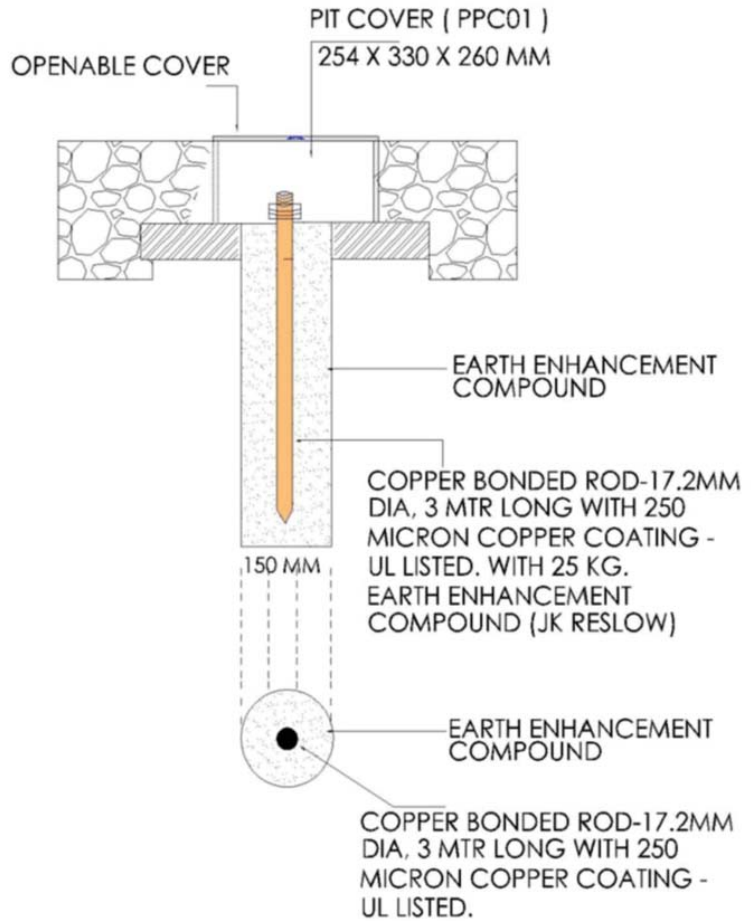

MODEL NO – JK 0110 CBR

Advance chemical gel earthing system for the proper dissipation of fault / leakage current to the ground and ensure the continuous electrical connectivity and proper functioning to the electrical system. The earth rod shall be of UL listed & CPRI tested 3 meter long 23.2 mm dia 250 microns copper bonded steel rod with the connecting clamp (ss - rod to tape). The UL listed copper bonded rod also should be tested & certified from CPRI for a short circuit current of 50 KA or more. The UL listing shall be punched / engraved on the rod for the physical verification at site.

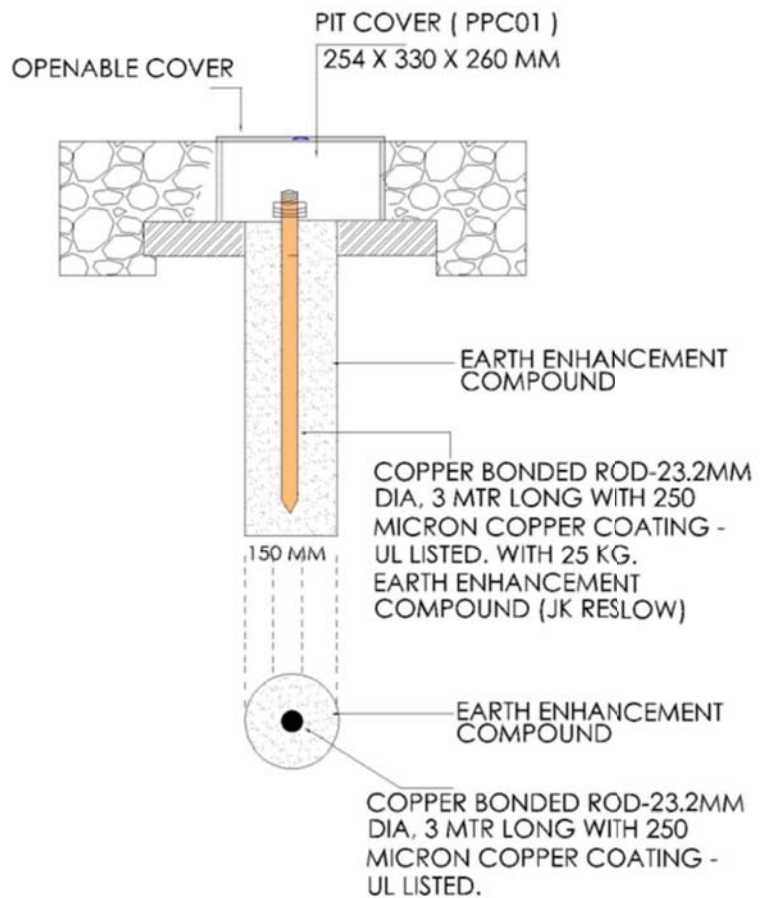

EARTHING CHEMICAL

JK RESLOW

To ensure the electrical conductivity resistance grounding minerals per earth pit / earth rod shall be used along with the copper bonded rod. The chemical compound shall be tested for the contents from NABL accredited laboratory in India. The testing laboratory shall be an ISO 9001 & ISO 14001 certified. As per IEEE 80-2013 (Clause 14.5 d), the grounding minerals shall be tested & certified for the resistivity of less than 0.12 ohm-mtr. The grounding minerals should be ROHS certified to ensure it does not pollute the ground water.



EARTH PIT CHAMBER

Each earth pit shall be covered with suitable heavy duty weather proof environment friendly Poly Plastic earth pit chamber with cover of auto-locking facility and tested from any Got of India laboratory for 9 tons load bearing capacity with the following dimensions - 254 mm dia. (top), 330 mm dia. (bottom) and 260 mm (height). 4 knock-out openings are provided for the easy interconnection of earth strips between the earth pits to form a grid.



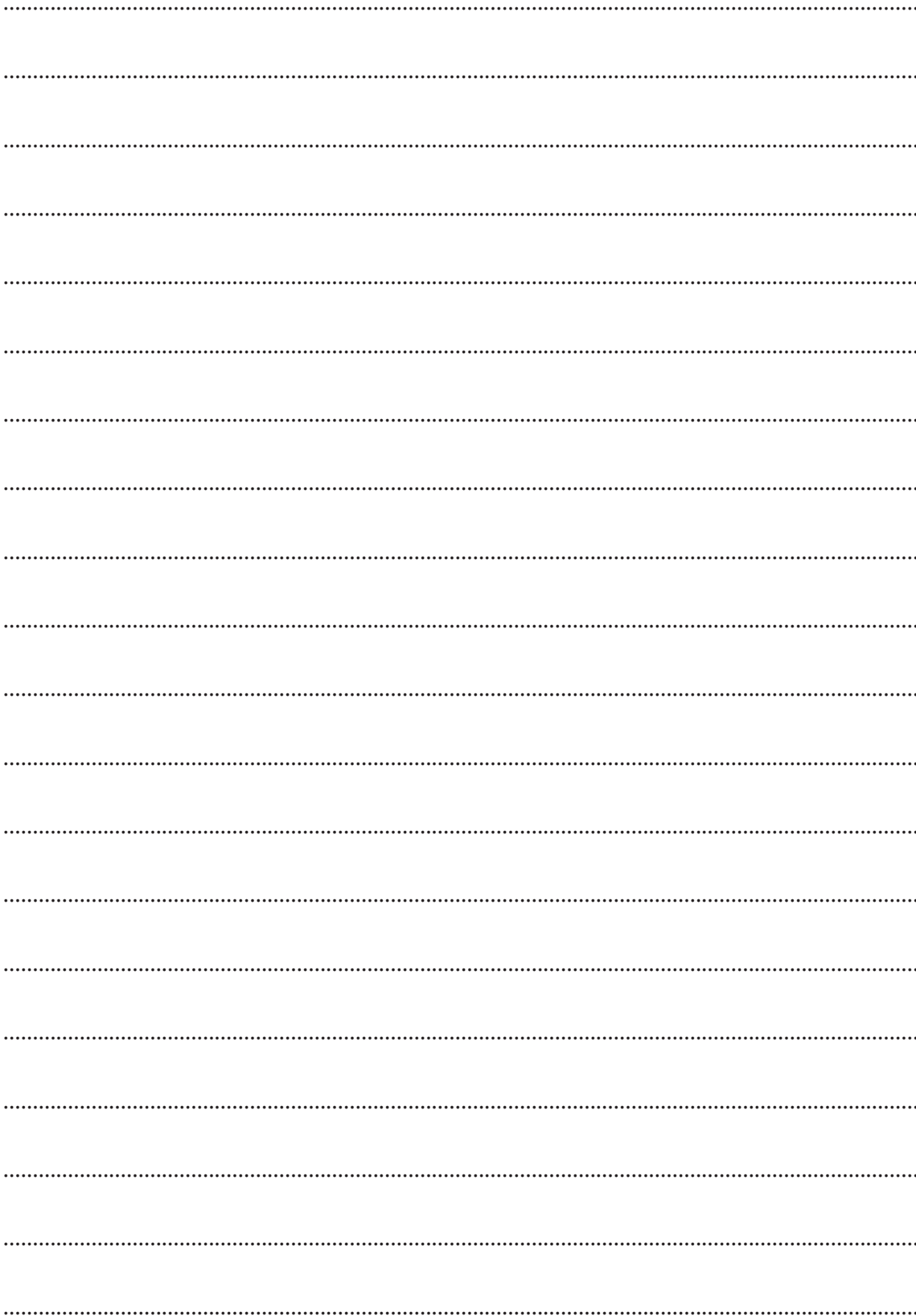



ALLIED POWER SOLUTIONS

T - 4, 5 & 6, Third Floor, Pankaj Plaza - 3, I.P. Extn., Patparganj, Delhi - 110 092 (INDIA) **t:** +91 11 2224 7322
e: info@alliedpowersolutions.com | **w:** www.alliedpowersolutions.com